

Multi Unwind Stands

Multiple Shaftless unwinds for sheeter applications. Individual tension system are for situations where the rewind rolls have inconsistent rewind tensions.

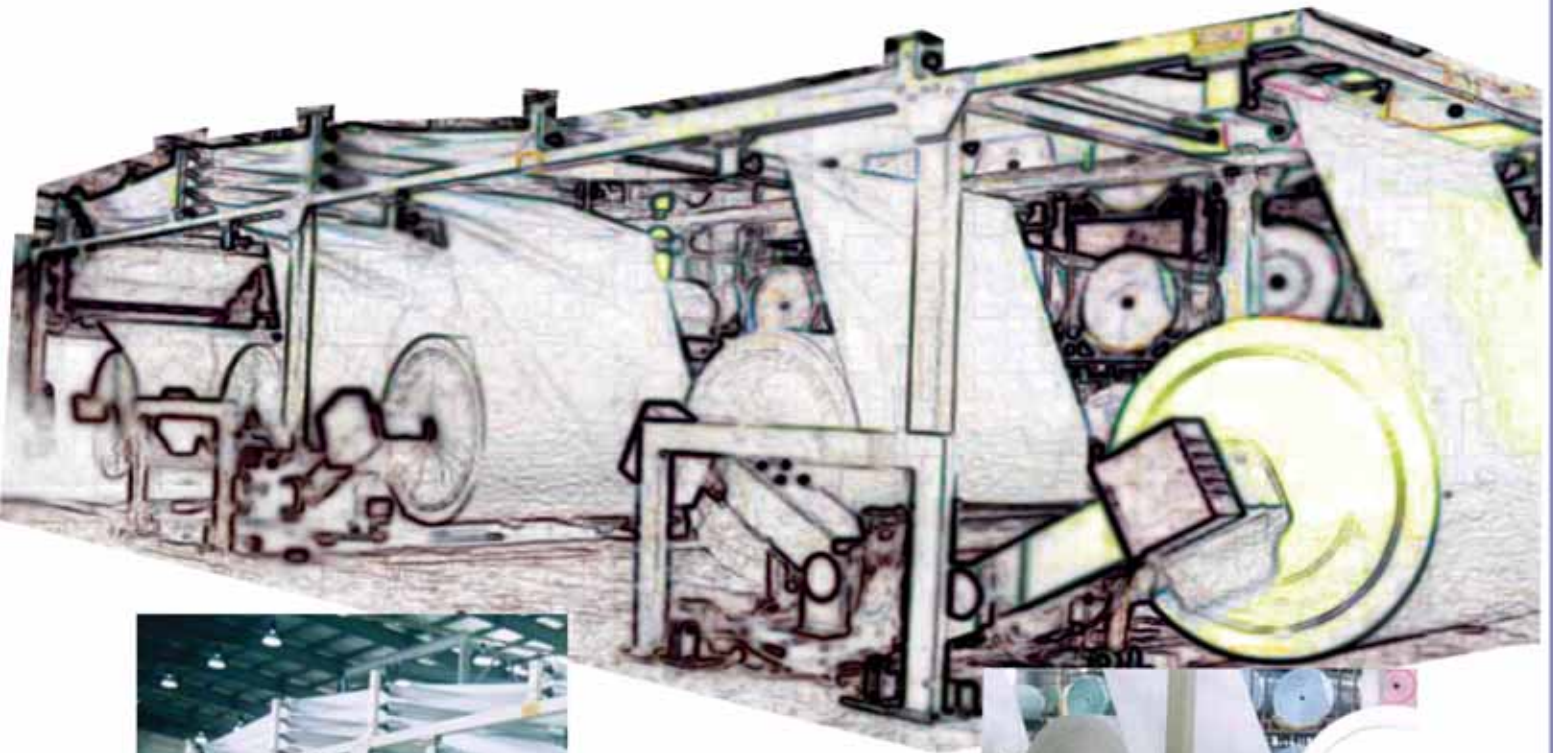

Overhead gantry for ease of paper feed.



Hydraulic lifting and side movement.

Overhead gantry ensures that the individual Web paths are separated until final nip rollers at the sheeter.

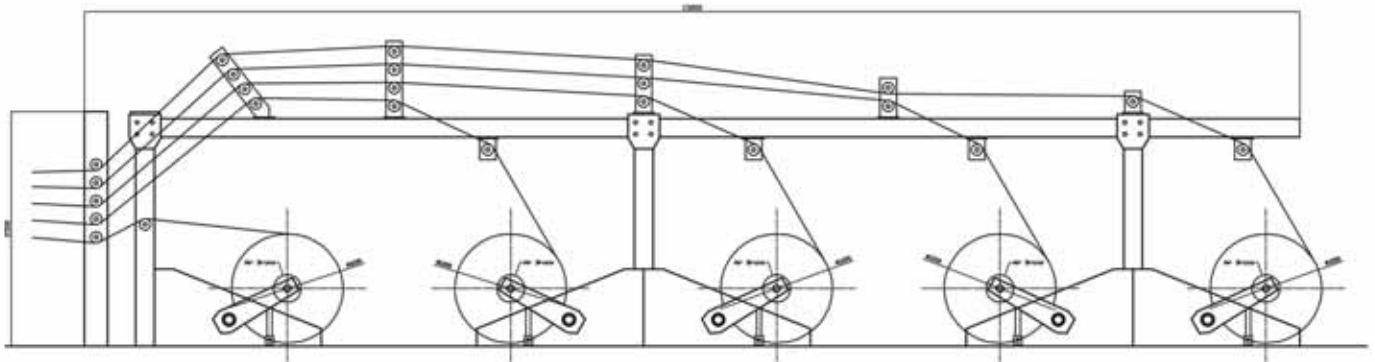

<i>Technical Parameters</i>	
* Max. material width	2000 mm
* Max. mechanical speed	300 m/min
* Parent roll : max.diameter	1200 mm

<i>Processed Material</i>	
* Paper :	18 - 200 gsm

